

Problem Solving Wall 200

A collection of graded
mathematical problems for
secondary school students

Jon O'Neill
Oliver Wilson



Foreword

Problem Solving Wall 200 is a collection of mathematical problems suitable for using with secondary school students.

The problems are a mixture of old classics, ancient riddles and modern-day puzzles.

We apologise for not naming or knowing the authors of these problems. Many are reconstructed from the vaguest of our memories. Others are listed on internet sites and often unattributed. Of note, the textbook 'Moscow Puzzles' contains many of the problems collected here. The collected works of Martin Gardner and Tony Gardiner also contain dozens of problems in this collection.

The level of mathematics required to access a problem can be approximately categorized by the following ratings:



Key Stage 2/3



Key Stage 3



Key Stage 4



Key Stage 4/5



Key Stage 5

This is really a very rough guide – and no doubt some of the problems will have been rated inaccurately by us.

No solutions are included. And hopefully most of the problems do not have easy to find solutions on the internet. This is intentional and it is hoped that the discussions and levels of 'proof' that students demonstrate with their solutions will be the better for there being no easy answer to hand.

It is a known phenomenon that some problems will appeal greatly to a solver whilst others simply hold no interest whatsoever. For that reason, we have found it profitable to display 20 or so problems at a time on classroom 'problem walls'. Students simply try a problem if it grabs their attention.

Also, we feel that students should not be assessed using these problems. The satisfaction that students get from completing a problem is reward enough. And failing at solving a problem is surely not possible. Simply engaging with the problem, persevering, and thinking deeply and creatively about a solution can be of great enjoyment. We have found that some of our students now share our passion for mathematics through attempting to solve our problem walls and we hope that more students will now have access to these classic problems through this modest collection.

Jon O'Neill and Oliver Wilson, Cairo, June 2014

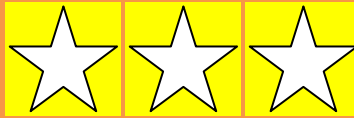

Earth's Circumference

At noon on the summer solstice the Sun is directly overhead in Syene (Aswan), whilst at the same time the Sun's elevation in Alexandria can be measured (with a stick's shadow) to be 7.2 degrees. Estimate the Earth's circumference if the distance between Syene and Alexandria is 5000 stades (1 stade \approx 157.5 metres)

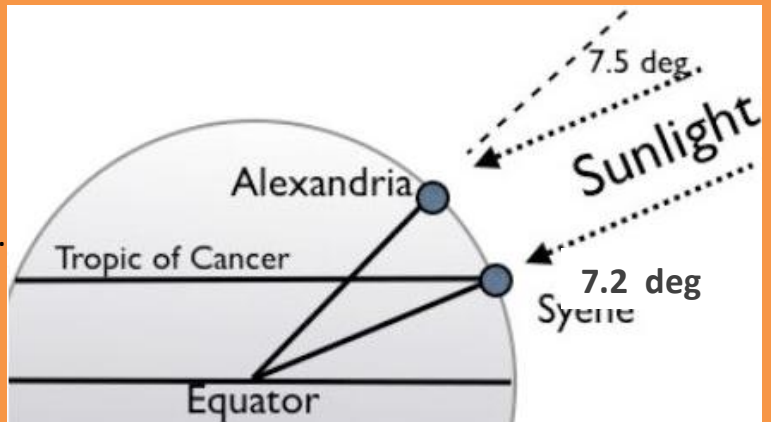

Sudoku (hard)

Fill in the grid so that every row, every column and every 3 x 3 box contains the numbers 1 to 9

	3		7	8	
		9			
8			6	1	4 5
	1 4				2
		5	2		
6				7 8	
2	3	8	9		1
				9	
	6		1		2



Tennis Pro

Alex estimates that he wins one point out of every three points when he plays his tennis club's professional.

What is Alex's chance of winning the first game?

What is Alex's chance of winning the first set?

What is Alex's chance of winning a 5-set match?



Jigsaw

A jigsaw has 64 pieces.

If joining together any two pieces is counted as 'one move' then what is the fewest number of moves needed to complete the jigsaw?



Sphere in a Cone

A right-circular cone has a base diameter of 12 units
and a slant-height of 10 cm.

What is the diameter of the largest sphere that can
fit entirely inside this cone?



Penalty Shootout

In major football tournaments, tied matches in knockout rounds
are decided by holding a penalty shootout.

Calculate an estimate for the average amount of time that is
needed to complete a penalty shootout.

You may assume that it takes 1 minute for each penalty to be taken,
and that the probability of scoring each penalty remains constant at 0.7

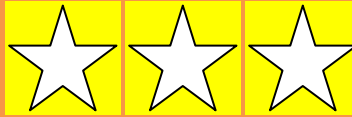

'Four' Questions

In how many different ways can:

- four letters A,B,C and D be used as the key to a 4-dial combination padlock
- four books be arranged on a shelf
- four guests sit a circular table
- four differently coloured beads be threaded on a circular loop of wire



Pyramid of Spheres

Four identical spheres of unit radius lie on a flat surface so that they form a square-like structure.

A fifth identical sphere is now placed on top so that is in contact with the other four spheres.

How high above the flat surface is the topmost part of the fifth sphere?



Eight Cubes

You have eight cubes which are identical except in colour.

Two are red, two are blue, two are green and two are yellow.

In how many different ways can these eight cubes be assembled to make a large cube?



Palindromic Numbers

12321 is a palindromic number.

Can you **prove** that all four-digit palindromic numbers are multiples of 11?



Two Shaded Circles

The large circle has a radius of one.

Inscribed in the circle is an equilateral triangle.

What are the radii of each of the shaded circles?

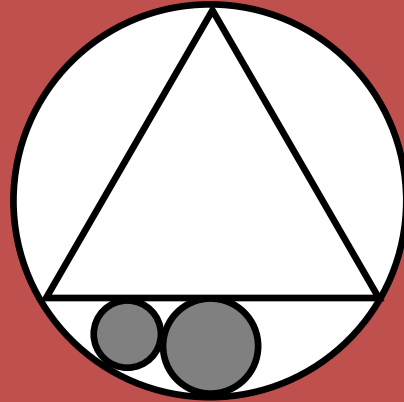

Odd Divisors

Which numbers have an odd number of divisors?



Skew Lines on a Cube

Lines S and T are skew face diagonals of a cube.

X is a point from the set of all points in line S.

Y is a point from the set of all points in line T.

Describe the set of midpoints of all possible line segments XY?

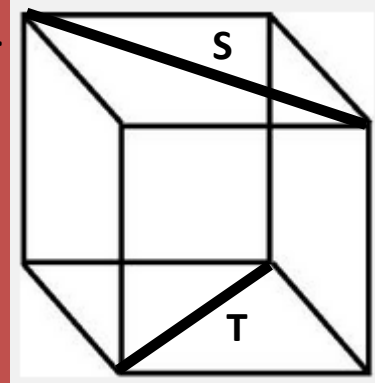

Shaded Circle

The large circle has a radius of one.

The line is a diameter of the large circle.

What is the radius of the shaded circle?

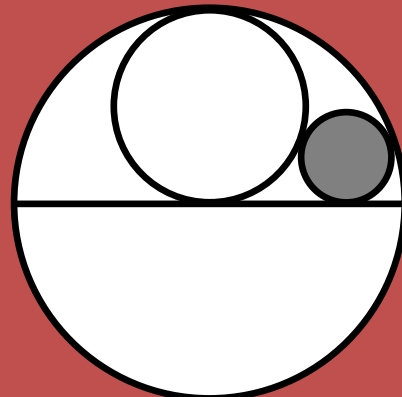



Triangle Problem

ABC is an equilateral triangle and P is a point in its interior.

The distances PA, PB and PC are 3, 4 and 5 respectively.

What is the side-length of the equilateral triangle?



Elevator Problem

There are seven elevators in apartment building.

Each elevator stops at no more than six floors.

The elevators are built so that it is possible to go from any one floor to any other floor using just a single elevator.

What is the maximum number of floors that the building can have?



Temple Art 3

The large square, of length a , contains a design made of arcs and circles.

Find the radii of both circles in terms of a .

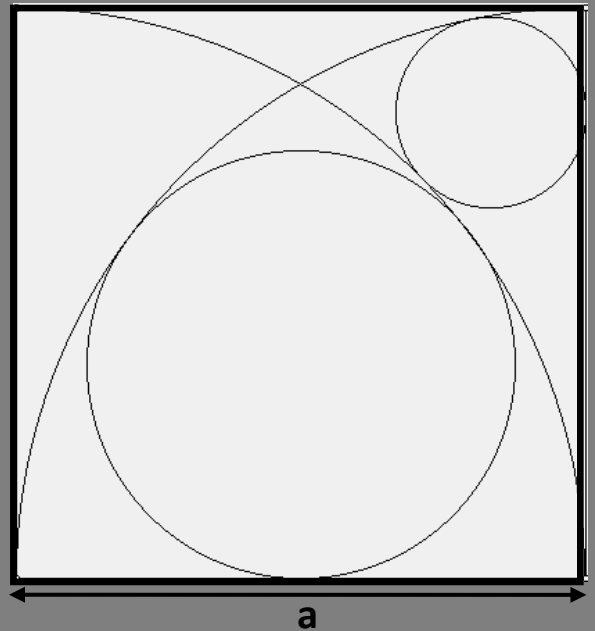

Multilingual Students

An international school has 250 students.

For every two students A and B , there is some language that A speaks that B doesn't speak, and some language that B speaks that A doesn't speak.

What is the smallest total number of languages that could be known by the students?



Temple Art 1

The large square, of length a , contains a design made of arcs, circles and a square.

Find the radii of both circles and the length of the square in terms of a .

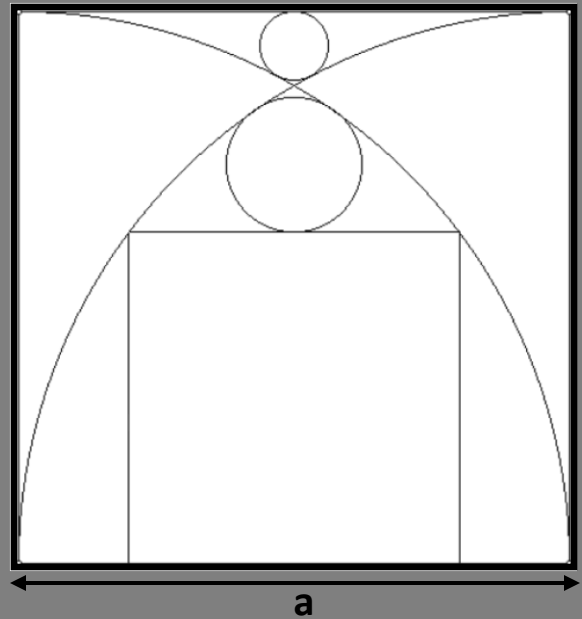

Temple Art 2

The large square, of length a , contains a design made of arcs and circles.

Find the radii of both circles in terms of a .

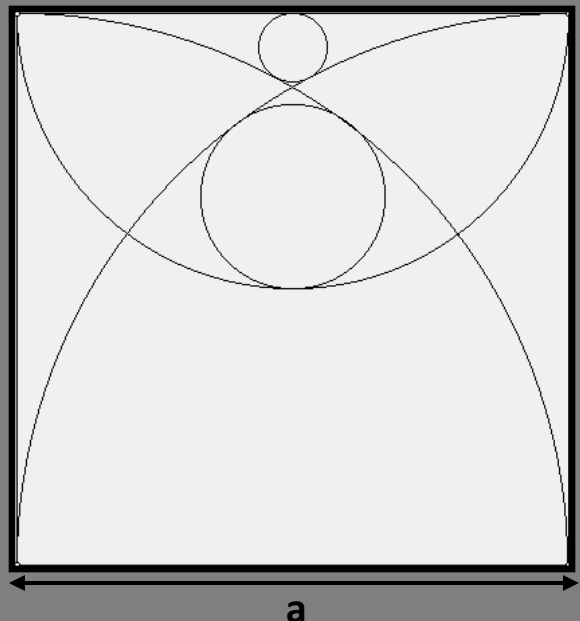



Cube in a Sphere

A sphere passes through the eight corners of a cube of side 10 cm.

Find the volume of the sphere.



Bridge and Torch

A group of four people need to cross a bridge.

It is night-time and it is necessary to use a torch. The group has only one torch. Also, the bridge is only strong enough to carry the weight of two people at a time. The four people walk at different speeds and can cross the bridge in 1, 2, 5 and 10 minutes respectively.

When two people cross together, sharing the torch, they walk at the speed of the slowest person.

How quickly can the four cross the bridge?



Folded Paper

A rectangular piece of paper 30 cm by 21 cm is folded so that opposite corners coincide.

How long is the crease?



Triangle & Semicircle

(area of triangular-curved region A) = (area of segment B)

Show that $\tan x = \frac{\pi}{4}$

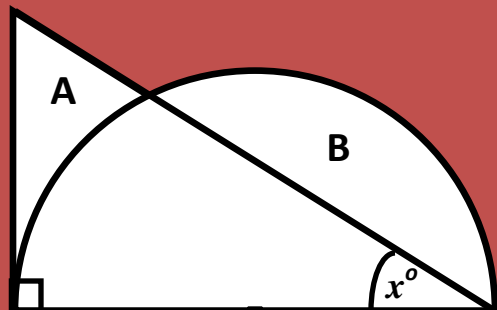



Special Offer

A can of soup carries a 'special offer' token.

When four tokens have been collected they can be exchanged for a free can of soup.

If you buy 64 cans of soup, how many free cans of soup will you be able to obtain?



Six Circles

The large circle has a radius of 10 cm

Find the radius of the small circle.

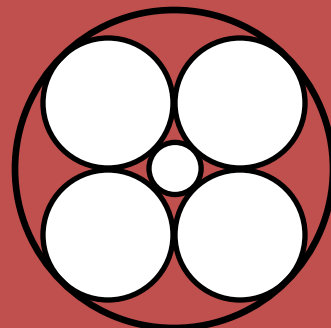



1000 term Series

Work out

$$1000 - 999 + 998 - 997 + 996 - \dots + 4 - 3 + 2 - 1$$

No calculator necessary!



Alphabet Product

Using the substitution $a=1, b=2, c=3, \dots, z=26$

evaluate the 26-term product

$$(a - x)(b - x)(c - x) \dots (z - x)$$



Perimeter of Hexagon

The squares in this diagram have unit length.

What is the perimeter of the hexagon?

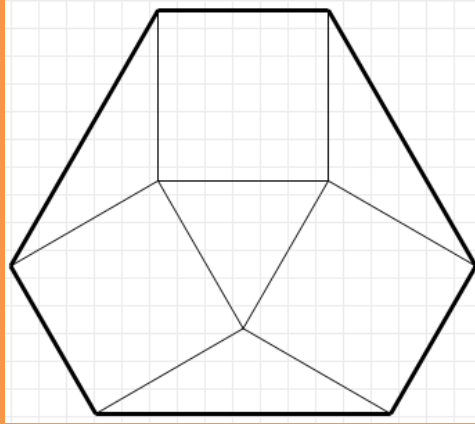

Million, Billion, Trillion

How many **days** would it take you to count from one to one million?

How many **years** would it take you to count from one to one billion?

How many **centuries** would it take you to count from one to one trillion?



Inscribed Circle

A circle is inscribed in a right-angled triangle with lengths a , b and c .

What is the radius of the circle in terms of a , b and c ?

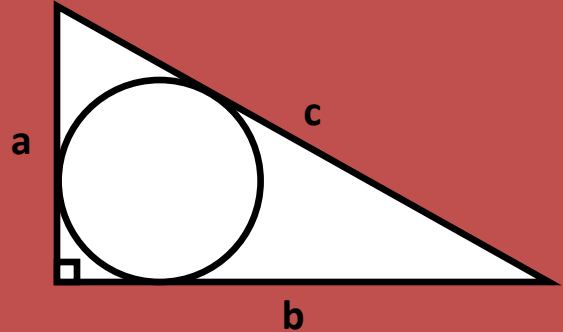

Triangles on a Grid

Three points are chosen at random on a 5 by 5 coordinate grid.

What is the probability that the three points will form a triangle?



Mean, Median, Mode

Find the unique set of whole numbers which have a
mean average of 4, a median average of 5 and
a mode average of 1.



Table and Boxes

The diagrams show a table with two identical wooden blocks.

Calculate the height of the table.

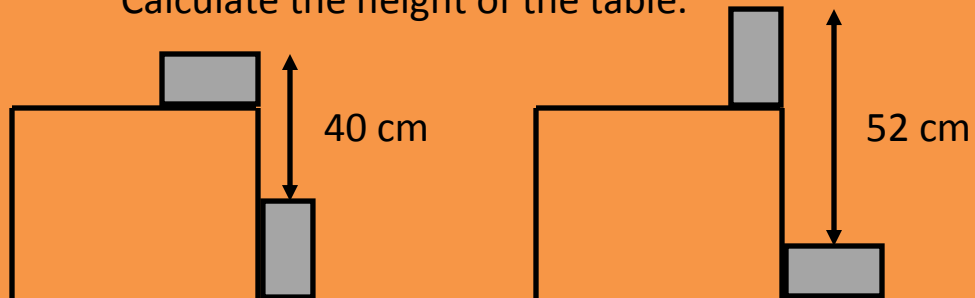



Writing to 1000

If you were to write down all the counting numbers from 1 to 1000, how many *digits* would you write down?

What if you were to write all the numbers from 1 to 10000?



How Many Triangles?

How many triangles are there in this diagram?

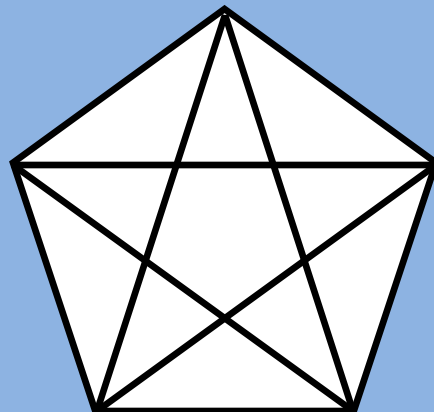



Electrical Engineer

Fibre-optic cables, with circular cross-section, are placed within a protective casing, also with circular cross-section.

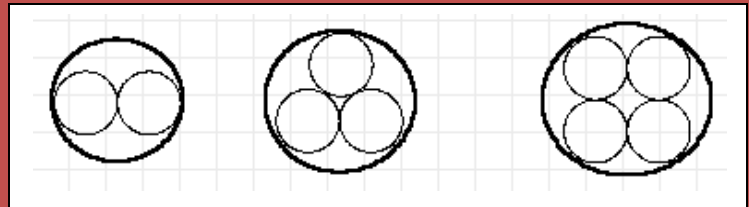

Given that the fibre-optic cables have a diameter of 2 cm, calculate the diameter of the protective casing that will hold 2, 3 and 4 fibre-optic cables.



Overlapping Triangles

Two congruent equilateral triangles are placed on top of each other so that the overlap forms a regular hexagon.

Each of the triangles has an area of 24 cm^2

Find the area of the hexagon.

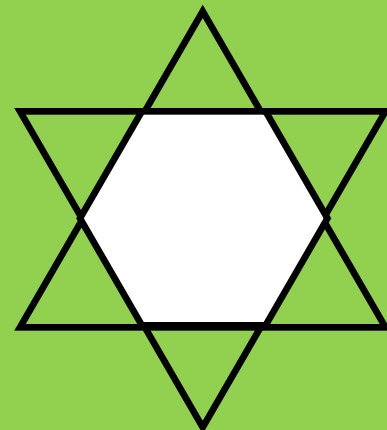



Codebreaker

K	E	Y
E	H	I
H	T	S
T	S	I

= KEHTEHTSYISI
= ?

?

= EGASASISSDNAIEEDTHMCODED
= ?



Squares on a Grid

How many squares can be drawn on a 4 by 4 grid?

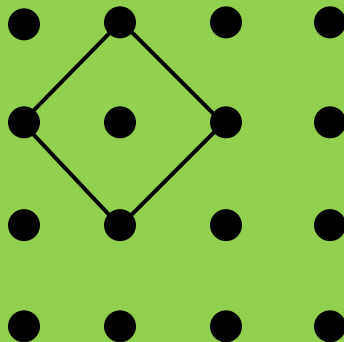



Seventeen Circles

Sixteen unit circles are placed as shown.

Find the radius of the shaded circle.

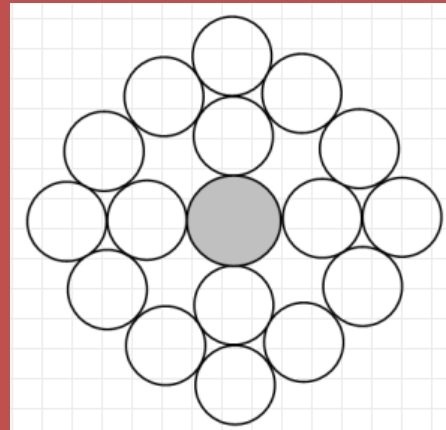

Octagonal Star

Each vertex of a square is joined to the midpoints of opposite sides to form an octagonal star. What fraction of the square is shaded?

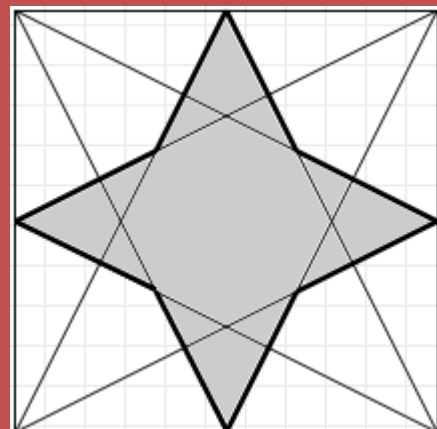



Consecutive Zeros

When the number $100!$ (one hundred factorial) is written out in full, how many consecutive zeros are there at the end of the number?

What about the number $1000!$



Surprising Cuboids

The 'perimeter' of a cuboid can be measured along three different axes.

One way is shown in the diagram.

Cuboid A has perimeters of 12cm, 16cm and 20cm

Cuboid B has perimeters of 12cm, 16cm and 24cm

Which cuboid has the greater volume?

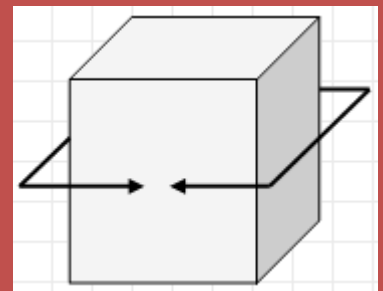



Parallelograms

Choose three points P , Q and R at random so that $OPQR$ forms a quadrilateral.

Prove that when the midpoints of each side of this quadrilateral are joined in order they always form a parallelogram.



Circles in a Corner

Two circles touch each other and two perpendicular lines.

The large circle has unit radius.

Find the radius of the small circle.

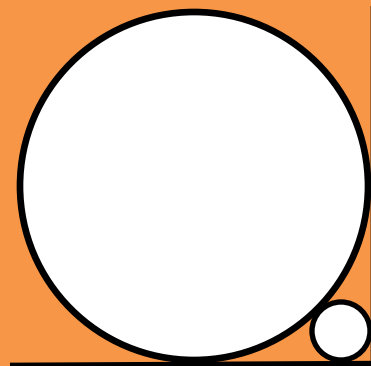



Quarter-Circles

Find the ratio of the shaded area to the area of the square.

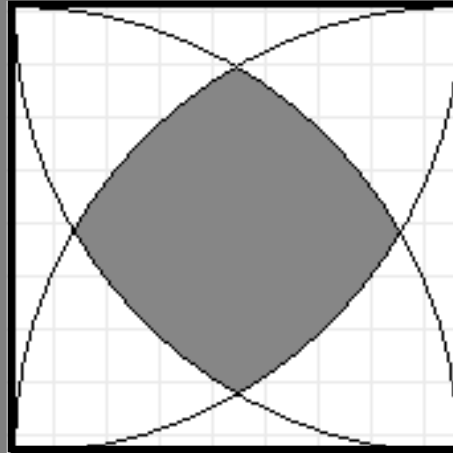

Tangent Equation

Show that for any non right-angled triangle

$$\tan A + \tan B + \tan C = \tan A \tan B \tan C$$



Sandglass Timers

When a sandglass is turned upside down, sand pours from the top section into the bottom section.

The amount of sand is measured carefully so that it takes an exact amount of time for all the sand to fall through.

Two different sand glasses have been designed to measure times of 9 minutes and 13 minutes respectively.

How could you use these to measure a time of 30 minutes?



Inscribed Circle

A circle is inscribed in an equilateral triangle.

Find the area of the triangle

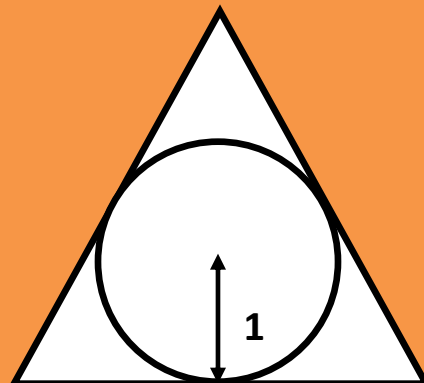



Spider and Fly

A room is in the shape of a cuboid with a length of 6 metres,
a width of 5 metres and a height of 3 metres.

A spider and a fly are at diametrically opposite corners of the room.

Find the shortest distance that the spider can crawl to catch the fly.



Absolute Equation

$|x|$ is called the absolute value of x

If x and y are integers, how many different solutions are there to

$$|x| + 2|y| = 20$$



Children's Slide

A slide is built by joining a ladder of length 3 metres to a chute 4 metres long.

The ladder is perpendicular to the chute.

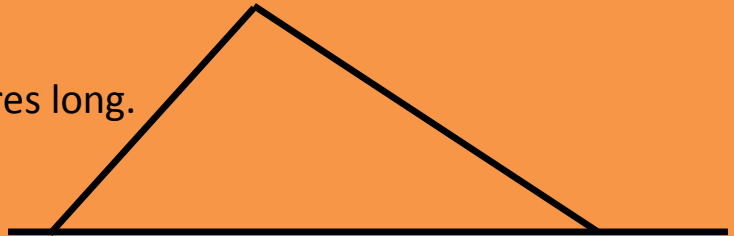

How high is the top of the slide?



Annulus

Find the area of the annulus.

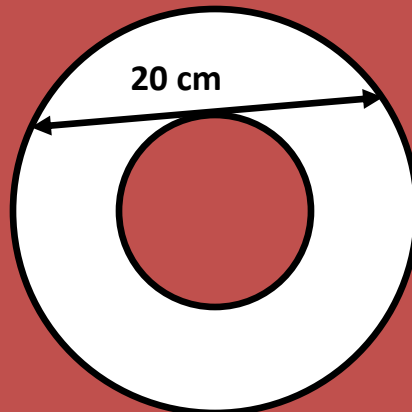



Circle in an Isosceles

A circle is inscribed in an isosceles triangle with lengths 5 cm, 5 cm and 6 cm.

Find the radius of the circle.

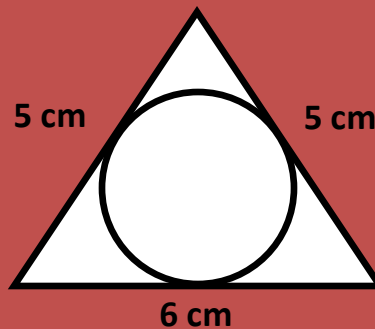

Triangle and Squares

A triangle is formed by joining together three squares.

What is the sum of the three external angles a° , b° and c° ?

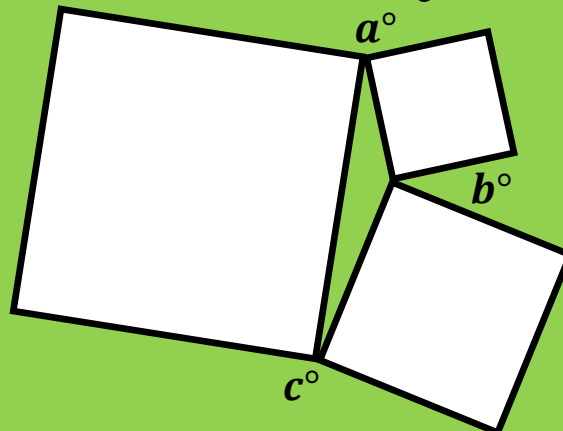



Shaded Square

Each corner of the square is joined by a straight line to a midpoint on the opposite edge.

What fraction of the square is shaded?

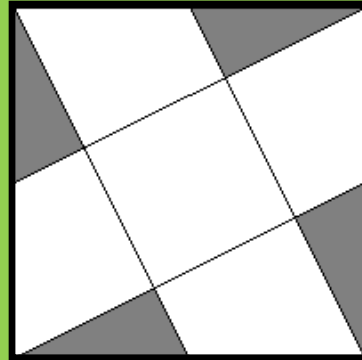

Broken Palm Tree

A vertically straight palm tree, 16 metres tall, snaps during a storm.

The top of the palm tree now lies 8 metres from its base.

Find the point at which the palm tree snapped.

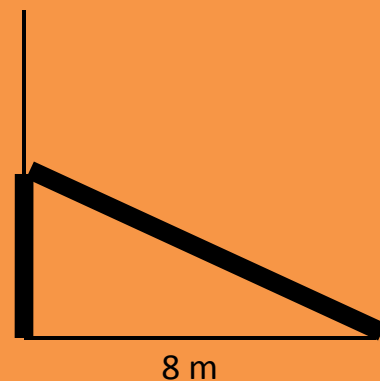



Three Squares

What fraction of the diagram is shaded?

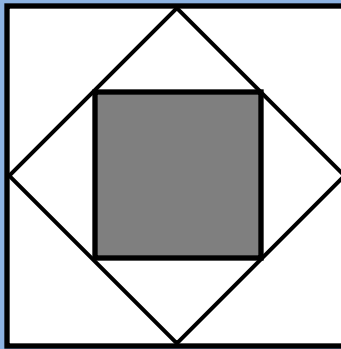

Partitions of 7

By using positive integers, how many ways can you make a sum that is equal to 7?

For example you could use

$$4 + 2 + 1 = 7$$

(Consider $5 + 2$ to be the same as $2 + 5$)



Product of Fractions

Work out the exact value of this product

$$\frac{1}{2} \times \frac{2}{3} \times \frac{3}{4} \times \frac{4}{5} \times \dots \times \frac{98}{99} \times \frac{99}{100}$$



Shaded Rectangle

What fraction of this rectangle is shaded?

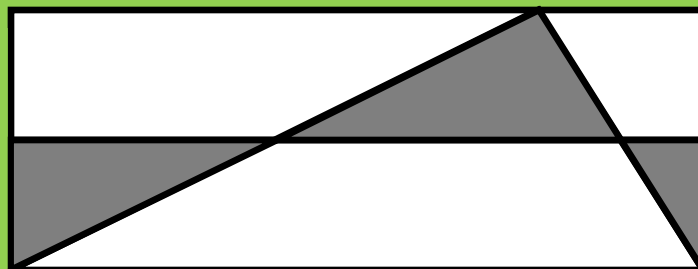



Earth's Curvature

The building with the World's highest public observation deck is the Canton Tower in Guangzhou, China. The deck is 488m above the ground.

How far from the foot of the Tower, measured along the surface of the Earth, is the horizon that an observer on the observation deck can see?

You may assume the Earth to be a perfect sphere with radius 6371 km



Gear Wheels

Gears are used in machines to increase or decrease rotational speed.

Find the speed in revolutions per minute (rpm) and the direction of rotation (clockwise or anti-clockwise) of each lettered cog in this diagram.

The number of teeth in each cog is given.

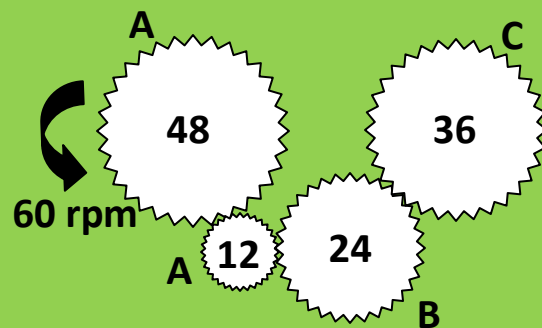



Greatest Product

What is the greatest product that can be made
by positive numbers that add up to 10 ?



Surd Fraction

Find the sum of these 100 fractions

$$\frac{1}{\sqrt{1}+\sqrt{2}} + \frac{1}{\sqrt{2}+\sqrt{3}} + \frac{1}{\sqrt{3}+\sqrt{4}} + \dots + \frac{1}{\sqrt{98}+\sqrt{99}} + \frac{1}{\sqrt{99}+\sqrt{100}}$$



Nested Surd

Calculate the **exact** value of this infinitely nested surd

$$\sqrt{9\sqrt{27\sqrt{128\sqrt{9\sqrt{27\sqrt{128\sqrt{\dots}}}}}}}$$



Fraction Pattern

Evaluate these **continued fractions** and discover a familiar pattern...

$$1, \frac{1}{1+1}, \frac{1}{1+\frac{1}{1+1}}, \frac{1}{1+\frac{1}{1+\frac{1}{1+1}}}, \frac{1}{1+\frac{1}{1+\frac{1}{1+\frac{1}{1+1}}}}, \dots$$

No calculator allowed!



Factorise

Factorise $x^3(y - z) + y^3(z - x) + z^3(x - y)$

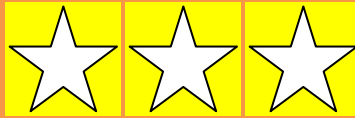

Last Digit

What is the last digit of

$7777777^{7777777}$

when the number is written out in full?



Simplify the Surd

Find the **exact** value of

$$\sqrt{2 + \sqrt{3}} - \sqrt{2 - \sqrt{3}}$$

The square root symbol signifies the positive square root only.

No calculator allowed!



Area and Perimeter

An isosceles triangle has a height of 8 cm
measured along its axis of symmetry,
and a perimeter of 32 cm.

What is its area?

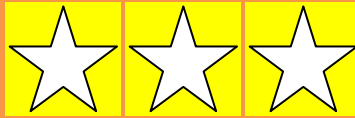

Eight-Pointed Star

The diagram shows a regular eight-pointed star.

What is the ratio of the shaded area to the un-shaded area?

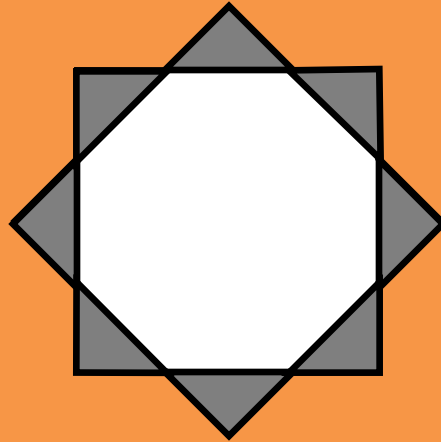

London to Cairo

London Heathrow Airport is at longitude 000.5° W and latitude 051.5° N

Cairo International Airport is at longitude 031.4° E and latitude 030.1° N

Taking the Earth to be a perfect sphere with a radius of 6378 km, calculate the surface distance between the airports of London and Cairo.

Calculate the distance of the flight-path from London to Cairo when a plane follows the most direct route and flies at an average altitude of 10,000 m.



Equilateral Interior

Select a point P to be anywhere inside the equilateral triangle.

What can be said about the sum of the perpendicular distances from P to each of the three sides of the triangle?

Can you prove this?

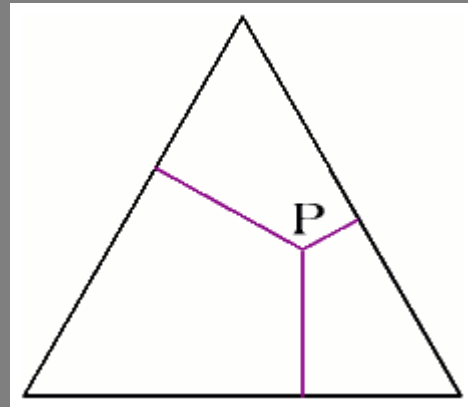

Cyclic Hexagon

A hexagon is inscribed inside a circle.

The sides of the hexagon are alternately a and b units in length.

What is the radius of the circle?

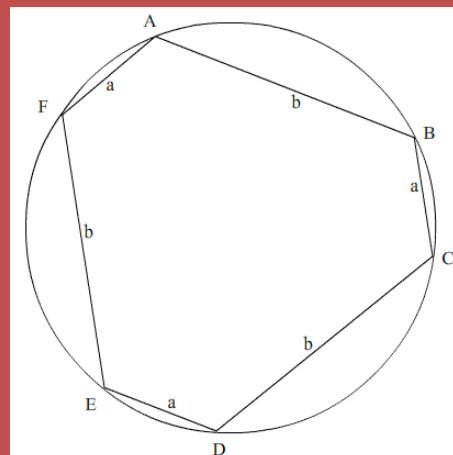



Chess Tournament

Eight players enter a 'round-robin' chess tournament.
This means that each player will play one game against each other player in the tournament.

How many games will each player play?
How many games in total will need to be played to complete the tournament?
What if it was a 'double round-robin' tournament?



Pentagonal Star

The diagram shows a regular pentagon.

The diagonals have been drawn to make a star.

What fraction of the area of the pentagon is the area of the star?

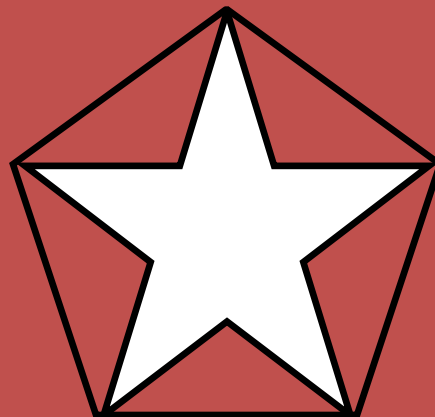



3×3 Magic Square

Using the digits 1 to 9 inclusive, fill this 3 × 3 square so that the each row, each column, and each of the two diagonals, add up to the same value.



4×4 Magic Square

Using the digits 1 to 16 inclusive, fill this 4 × 4 square so that the each row, each column, and each of the two diagonals, add up to the same value.



Unfriendly?

You have to sit at a large, circular table at which three people you do not like are already seated.

Where should you place your chair at the table so that when you add up the distances around the edge of the table from each of the three people to yourself, the total distance you get is as large as possible?



Latin Square

Using the digits 1 to 8 inclusive, fill this 8×8 square so that each digit occurs exactly once in each of the eight rows and exactly once in each of the eight columns.

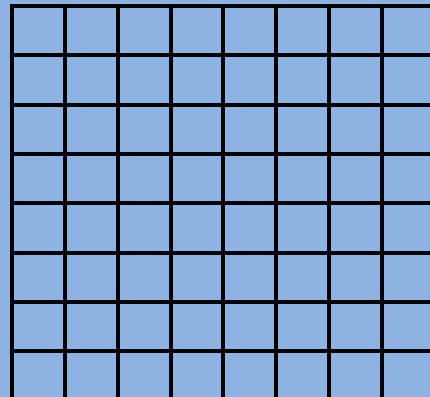

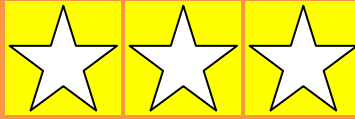

Two Coins

A box contains two coins.

One coin is heads on both sides,
the other is heads on one side and tails on the other.

One coin is chosen at random and the face of one side is noted.
If the face shows heads, what is the probability
that the other side is also heads?



Seven Reciprocals

Find seven distinct positive integers
whose reciprocals add up to one.

$$\frac{1}{a} + \frac{1}{b} + \frac{1}{c} + \frac{1}{d} + \frac{1}{e} + \frac{1}{f} + \frac{1}{g} = 1$$



Horse Racing

You are in charge of arranging races for 25 horses on a track upon which only five horses can run at a time.

Each horse always runs the distance in the same time, and every horse has a distinct time. You have no stopwatch - or any other method of accurately recording the times - but you can make deductions based on the finishing order of the horses of the races you organize.

What is the fewest number of races you need to organize in order to determine the fastest three horses in order?



Shaded Star

The diagram shows a regular pentagonal star.

What fraction of the area of the star is shaded?





Sports Day

In how many different ways, including ties, can four house teams be placed at the end of a Sports Day?

For example, two houses, Red and Blue, can finish in three different ways:
Red wins, Blue wins, or Red and Blue tie



Rail Maze

The map shows a railway maze – trains follow the track, and at each junction the train must follow the curve of the track.

Trains can only move forwards.

Can you find the **unique** route that connects station A to station B?

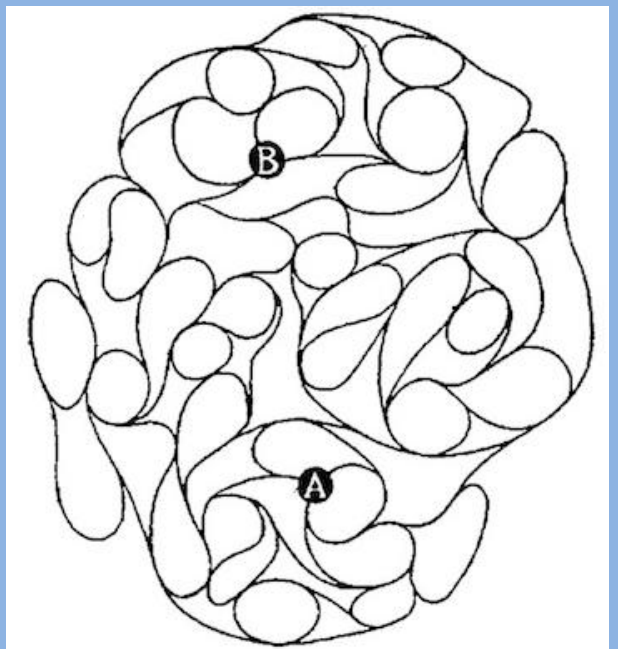



Trapezium Area

A trapezium is divided into four triangles by joining its diagonals.

The areas of the two triangles are as shown.

What is the area of the trapezium?

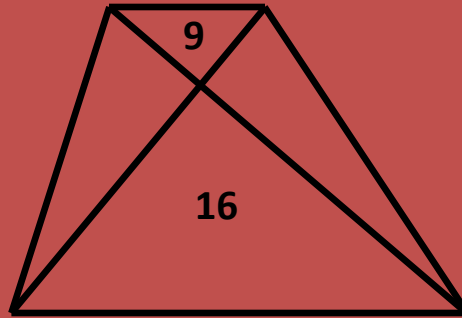

More Tails

Player A has one more coin than Player B.

Both players toss their coins and the player with the most tails wins.

What is the probability that Player A will score more tails than Player B?



World Cup Stickers

I need 640 stickers to complete my World Cup sticker album.

I can buy packets of stickers that contain five random stickers.

How many packets of stickers will I need to buy so that
I can expect to complete my album?

(Assume I cannot swap any 'doubles' with my friends)



Big Field

What is the largest area of a flat field that can be fully
enclosed by four straight fences
of length 20m, 40m, 60m and 80m ?



Dodecahedron Volume

What is the **exact** volume of a regular dodecahedron
with edges of unit length ?



Octahedron Volume

What is the **exact** volume of a regular octahedron
with edges of unit length ?



Fake Gold Coin

You have a balance-scale with two pans.

With one weighing there are three possible outcomes: the left-side is heavier, the right-side is heavier or the two sides have the same weight.



You are given a collection of twelve gold coins but you know that one is fake.

The coins look identical but the fake coin is either lighter or heavier than a real coin.

Show how to determine which gold coin is fake, and whether it is lighter or heavier than a real coin, using **only at most three** weighings on the balance.



Tetrahedron Volume

What is the **exact** volume of a regular tetrahedron with edges of unit length ?



Fair Dice Game?

Albert and Betty are playing a dice game.
They roll two, normal, six-sided dice and add them together.

Albert wins if a score of twelve comes up.
Betty wins if a score of seven comes up on two consecutive throws.

They keep rolling the dice until someone wins.

What is the probability that Albert will win the game?



Area of a Pentagon

What is the **exact** area of a regular pentagon
with sides of unit length ?



Shaded Triangle

The diagram shows an equilateral triangle with its corners at the mid-points of alternate sides of a regular hexagon.

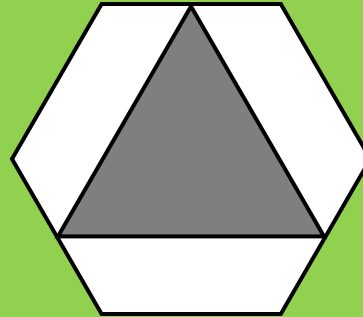

What fraction of the area of the hexagon is shaded?



Area X

The areas of each region are as shown.

Find the area x .

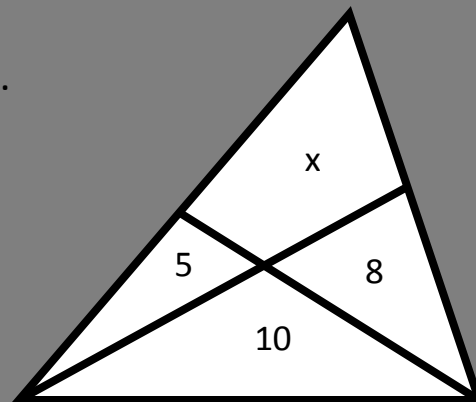



Four Spheres

Three identical spheres of unit radius lie on a flat surface so that they are all touching each other.

A fourth identical sphere is now placed on top so that all four spheres are in contact with each other.

How high above the flat surface is the centre of the fourth sphere?



Infinite Coins

An infinite number of coins are placed together to cover an infinite plane surface as shown.

What fraction of the plane remains uncovered?

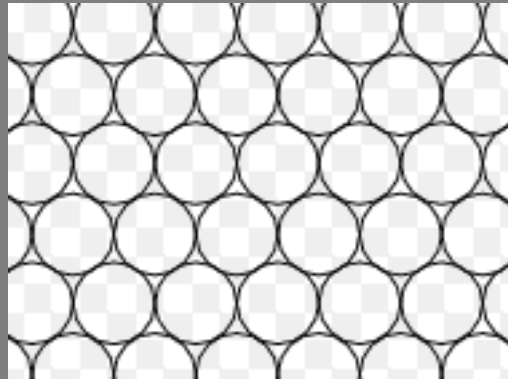



Ladders

Two ladders, AC and BD , are leant against opposing walls.

AB , EF and DC are perpendicular to BC .

AEC and BED are straight lines.

$AB=x$, $EF=h$ and $DC=y$.

Find h in terms of x and y .

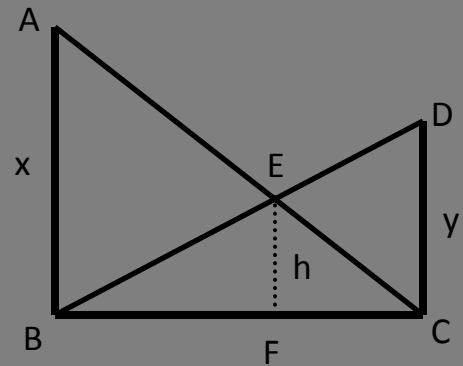

Coloured Tiles

A square tile is divided into four triangles by joining the diagonals.

How many different ways are there to colour the tile if only three colours are available?

Tiles which are identical under rotations and reflections are not to be counted.



Five Squares

Show that the area of the triangle T is equal to the area of the square S

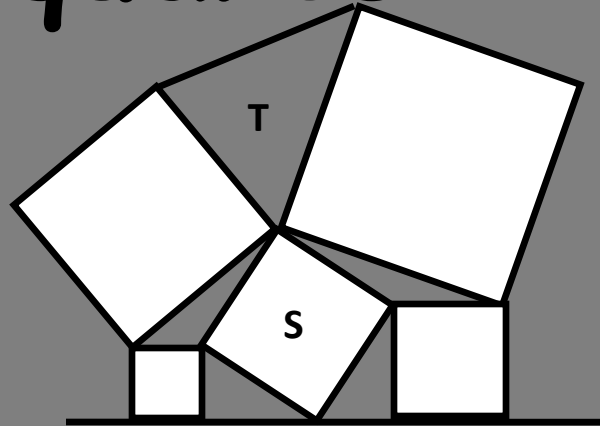

Five Circles

Five circles are tangent to two non-parallel lines.

The smallest circle has a radius of 4 cm, and the largest circle has a radius of 9 cm.

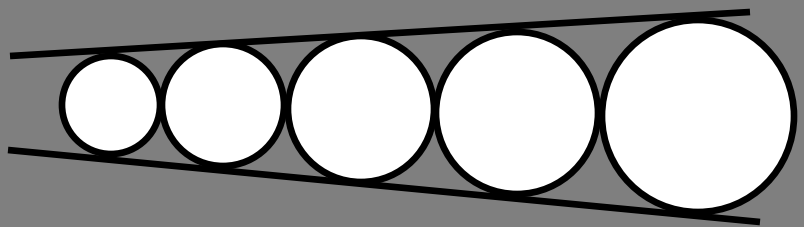

What is the radius of the middle circle?



Broken Stick

A stick is broken into three pieces, at random.

What is the probability that these three pieces can form to make a triangle?



Rolling Circle

The diagram shows a circle with circumference 1 being rolled around an equilateral triangle with sides of length 1.

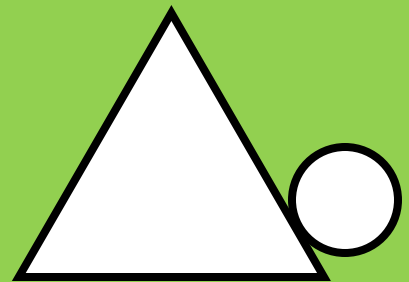

How many complete turns does the circle make as it rolls around the triangle without slipping?



Inscribed Squares

Which of these squares inscribed in a regular pentagon has the largest area?

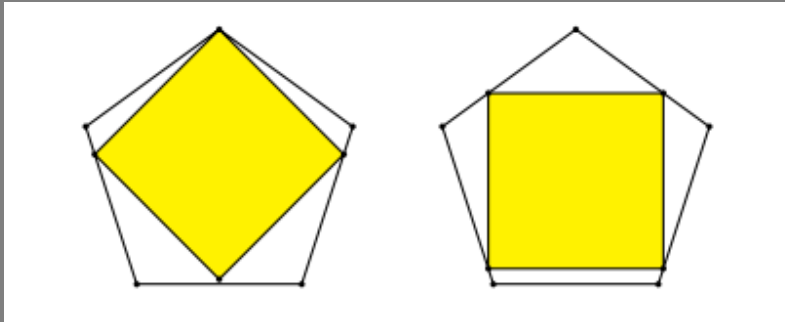

Triangles

Choose three points at random and draw a triangle.

What is the probability that the triangle is an acute-angled triangle?



Five Circles

Four small circles of radius 1 cm are tangent to each other and also to the larger circle that contains them.

What is the area of the region inside the larger circle but outside all of the smaller circles?

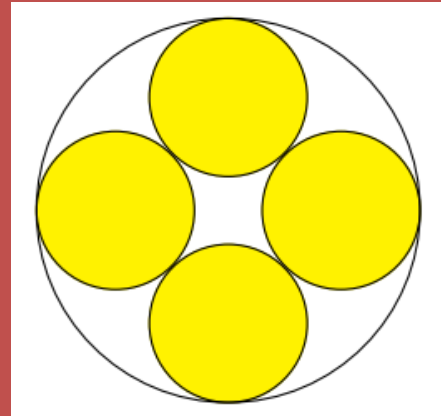

Inscribed Triangles

Which of these equilateral triangles inscribed in a regular pentagon has the largest area?

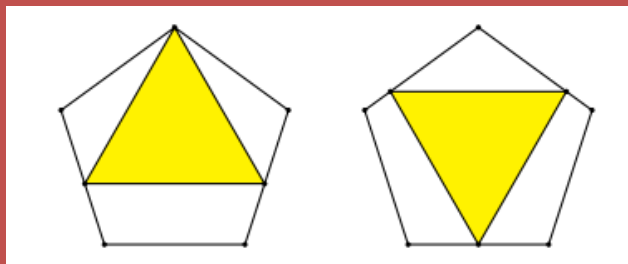



Counterfeit Coin

You have a balance-scale with two pans.

With one weighing there are three possible outcomes: the left-side is heavier, the right-side is heavier or the two sides have the same weight.



You are given a collection of nine coins but you know that one is counterfeit.

The coins look identical but the counterfeit coin is lighter than a normal coin.

Show how to determine which coin is counterfeit using **only at most two** weighings on the balance.



Circles in a Rectangle

Two circles, of radius 17 cm and 9 cm, are enclosed in a rectangle with a longest side of length 50 cm.

The two circles touch each other, and each circle touches adjacent sides of the rectangle as shown.

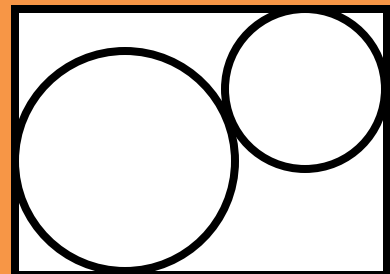

Find the area of the rectangle.



Flight of a Bumblebee

Two trains 100 km apart are travelling towards each other along a straight piece of track.

The first train is travelling at 30 km/h and the second train is travelling at 20 km/h.

A bumblebee hovering just in front of the first train sets off and flies to meet the second train. When it arrives it turns around and flies back to meet the first train.

It turns around again and goes on flying back and forth between the two trains until the two trains collide.

If the bumblebee can fly at 50 km/h, how far will it fly until it meets its tragic end?



Ferry Boats

Two ferry boats cross a river in opposite directions at right-angles to the river bank and return to their starting places.

Each ferry boat travels at a constant speed though the two speeds are different.

On the way across they meet 720 yards from the nearest river bank.

On the way back they meet 400 yards from the other river bank.

How wide is the river?

(there are 1760 yards in a mile)



Crescent

The diagram shows a crescent made from two circles.

O is the centre of the large circle.

Find the diameter of the large circle and the diameter of the small circle.

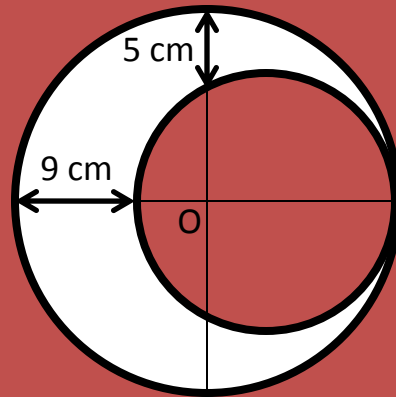

diagram
not to scale



Goat in a Field

A goat is placed in a field of grass that has an area of one hectare.

The field is in the shape of an equilateral triangle.

The goat is tied with some rope to a post at one corner of the field.

What should the length of the rope be so that the goat should be able to eat just half of the grass in the field?

You may assume that the goat can feed to the end of the piece of rope.

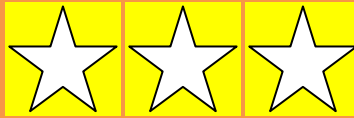

Futoshiki (hard)

Fill in the grid so that every row and every column contains the numbers 1 – 6.

The 'greater than' and 'less than' signs indicate where a number is larger or smaller than its neighbour.

				5	
			>		>
^	^			<	^
		5			
	>			^	6
^				^	
			3		
		^			
3					



Logic Quiz

Q1. Which is the first question where c) is the correct answer?

- a) Q3 b) Q4 c) Q1 d) Q2

Q2. Which is the first question where a) is the correct answer?

- a) Q4 b) Q2 c) Q3 d) Q1

Q3. Which is the first question where d) is the correct answer?

- a) Q1 b) Q2 c) Q4 d) Q3

Q4. Which is the first question where b) is the correct answer?

- a) Q2 b) Q4 c) Q3 d) Q1



Futoshiki (standard)

Fill in the grid so that every row and every column contains the numbers 1 – 4.

The 'greater than' and 'less than' signs indicate where a number is larger or smaller than its neighbour.

	<		>
2		>	
4	2		^



Futoshiki (medium)

Fill in the grid so that every row and every column contains the numbers 1 – 5.

The 'greater than' and 'less than' signs indicate where a number is larger or smaller than its neighbour.

3				
			∨	
^				
	<	<		
			<	
4	>	^	>	3



Tennis Balls

Tennis balls are often sold in a sealed tube of three.

Which of these lengths is longer?

- the height of the tube
- or
- the distance around the tube



Three Circles

The radius of the large circle is p cm

The radius of the medium circle is q cm

What is the radius of the small circle?

Give your answer in terms of p and q

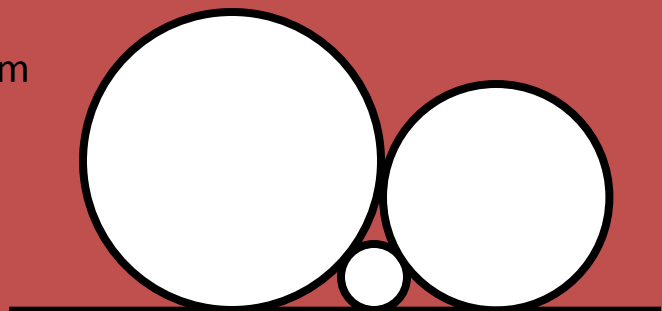



Millionaire?

You have won a competition.

The prize is to take home as much money as you can carry – on your own and without any help.

There is a pile of one million \$1-banknotes.

How much money can you carry?



Noughts and Crosses

How many winning lines are there in the game of noughts and crosses?

Imagine a three-dimensional game of noughts and crosses.

How many winning lines are there in this game?



Challenging Geometry

Find the size of the angle x

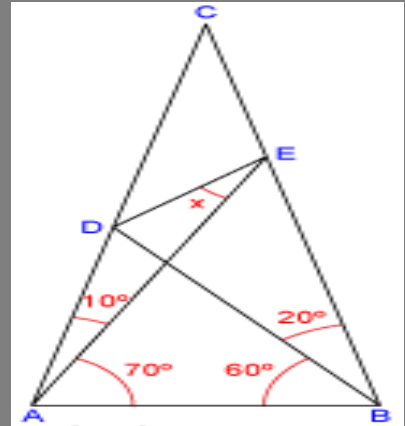

You are the Doctor

Your patient has tested positively for a deadly disease.

There is a treatment available which has a 99% chance of curing the patient, but the side-effects of the treatment cause fatalities in 10% of all cases.

It is estimated that 0.01% of the population has this deadly disease and that the test is 99% reliable.

Of people who actually have the disease, 99% test positive.

Of people who do not actually have the disease, 99% test negative.

Do you advise your patient to take the treatment?



Decimal Weekends

A standard week of school is
5 days of school followed by a 2 day weekend

A decimal week of school is
7 days of school followed by a 3 day weekend

Which would you prefer, and why?



Brothers and Sisters

A boy has as many sisters as brothers, but each sister has only half as many sisters as brothers.

How many brothers and sisters are there in the family?



Lemonade

I mixed up some lemonade in two glasses.

The first glass had 200 ml of lemon juice and 300 ml of water.

The second glass had 100 ml of lemon juice and 200 ml of water.

- Which glass had the stronger tasting lemonade?
 - How do you know?



Decimal Seconds

Standard Time divides a day into 24 hours, each hour into 60 minutes, and each minute into 60 seconds.

Decimal Time (French Revolutionary Time) divides a day into 10 decimal hours, each hour into 100 decimal minutes, and each minute into 100 decimal seconds

- Which is shorter, a standard second or a decimal second?
- Simplify the ratio, standard second : decimal second



Broken Bridge

Your platoon of soldiers must cross a river.

The bridge is broken and the river is deep.

You spot two boys playing in a rowboat near the shore.

The boat is so tiny however that it can only hold two boys or one soldier.

How can you get your platoon of soldiers successfully across the river?



Roman Lawyer

A Roman soldier is about to go to battle. His wife is with child.

The soldier owns 84 gold coins. He makes a will.

If a son is born, the son will inherit double the amount that the mother will receive, whilst if a daughter is born, the mother will inherit double the amount that the daughter receives.

The soldier goes to battle and dies.

The mother gives birth to twins, a boy and a girl.

How would you divide up the inheritance fairly?



False Statements

- The number of false statements here is one.
- The number of false statements here is two.
- The number of false statements here is three.
- The number of false statements here is four.

Which of the above four statements is true?



Water Pots

A cook has two empty pots:

- A pot that holds exactly 5 litres
- A pot that holds exactly 3 litres

Show how the cook can use these two pots to measure out exactly 4 litres of water



Cut the Cake

Show how you can cut a traditional circular cake
into eight identically equal size pieces
using only three straight cuts.



River Crossing

A man needs to cross a river in a canoe.
With him, he has a cabbage, a goat, and a wolf.
He can only carry one of the three at a time.
If he takes the wolf, the goat will be left with the cabbage and will eat it.
If he takes the cabbage, the wolf will be left with the goat and will eat it.
How does he successfully cross the river with his load?



Old Cryptarithm

$$\frac{EVE}{DID} = .TALKTALKTALK \dots$$

In a cryptarithm the same letters stand for the same digits, zero included.

Find the **unique** solution to this recurring decimal cryptarithm.

You may assume the fraction $\frac{EVE}{DID}$ has been reduced to its lowest terms.



Descriptor-digit

0 1 2 3 4 5 6 7 8 9

--	--	--	--	--	--	--	--	--	--

The ten cells inscribe a 10-digit number such that:

the digit in the first cell indicates the total number of zeros in the whole number

the digit in the second cell indicates the total number of ones in the whole number

...and so on until the last cell which indicates the number of nines in the whole number

Find the **unique** solution.



Orange Juice

I have a litre of orange juice.

I drink half of it then give it to you.

You drink half of what is remaining and then pass it back to me.

I drink half of what is remaining and give it back to you.

This process continues forever.

How many litres of orange juice did I drink in total?



Three Squares

Prove that the angle C is equal to the sum of the angles A and B

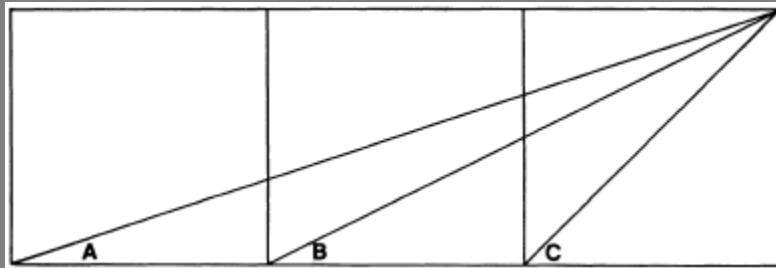

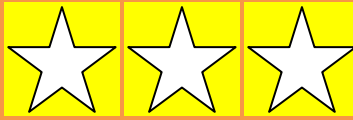

Truth-tellers & Liars

In a strange land there are two types of people:

Truth-tellers who always tell the truth and **Liars** who always lie.

The first man you meet says 'I am a Truth-teller.' Now decide, is he a Truth-teller or a Liar?

Later on you meet a boy and a girl.

You ask 'How many of you are Truth-tellers?'

The boy says 'One of us is a Truth-teller.' The girl immediately responds 'That is not true.'

Can you work out what type of people the boy and the girl are?



Car Tyres

A car has five tyres – four on the road wheels and one on the spare tyre.

The car travels 30 000 km and all five tyres are used equally.

How many kilometres' wear does each tyre receive?

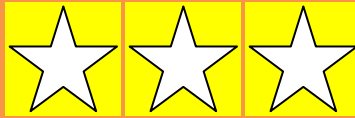

Fair Cakes

Show how to cut 3 identical circular cakes into 12 pieces so that 4 people each receive **identical portions**.

Find **three** different ways of doing this.

You may only cut the cakes in the normal way, that is, into sectors.

Identical portions means that everyone receives their fair share with different people receiving identical-looking portions.



Weighting Room

Albert, Brenda and Carla refused to be weighed on their own so the doctor persuaded them to be weighed in pairs instead.

- Albert and Brenda weighed 76 kg together.
- Brenda and Carla weighed 87kg together.
- Albert and Carla weighed 98kg together.

What are their individual weights?



Football Manager

You have been appointed the manager of the Averageville football team.

There are two other teams in your city, Strongpark and Weaklands.

Strongpark is the strongest team.

To keep your job you must win **two consecutive** games.

Which of these two fixture lists gives you the best chance to keep your job?

List A: Game 1 v Strongpark, Game 2 v Weaklands, Game 3 v Strongpark

List B: Game 1 v Weaklands, Game 2 v Strongpark, Game 3 v Weaklands



Exam Grades

In last year's Maths exams

Half the class got A's

One-third of the rest got B's

One-quarter of the remainder got C's

One-fifth of the others got D's

What fraction of the class got E's or worse?

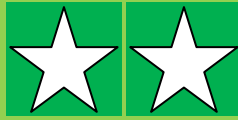

Cuboids

- The different faces of a cuboid have areas of 20 cm^2 , 24 cm^2 and 30 cm^2 .
What are the lengths of the edges and the volume of the cuboid?
 - Another cuboid has a total surface area of 400 cm^2 .
If the base of the cuboid is 4 cm by 8 cm, what is its height?



Rectangular Cuts

In a rectangle ABCD the point M is the mid-point of AD. Explain how you can

- draw a straight line through the point M to divide the rectangle into two parts with equal area
- draw a straight line through the point M to cut off one-quarter of the total area
- draw a straight line through the point M to cut off one-third of the total area



Triangular Duel

Smith, Brown and Jones agree to fight a pistol duel under the following unusual conditions. After drawing lots to decide who shall fire first, second and third, they take their places at the corners of an equilateral triangle. It is agreed that they will fire shots in turn and continue in the same cyclic order until two of them are dead. At each turn the man who is firing may aim at whoever he pleases.

All three duelists know that Smith always hits his target, Brown is 80 percent accurate and Jones is 50 percent accurate.

Who has the best chance to survive and what is the probability each man has of surviving?



Long Division Digits

Work out the missing digits in this division question

$$\begin{array}{r} \square \square \square \square \square \\ \square \square \square \overline{) \square \square \square \square \square \square \square \square \square} \\ \underline{\square \square \square} \\ \square \square \square \square \square \square \square \square \square \\ \underline{\square \square \square} \\ \square \square \square \square \square \square \square \square \square \\ \underline{\square \square \square} \\ \square \square \square \square \square \square \square \square \square \\ \underline{\square \square \square} \\ \square \square \square \square \square \square \square \square \square \end{array}$$



Hard Worker

When someone wants to hammer a nail into each of several posts placed at equal distances along a straight road, the best way is to begin with the first post and end with the last.

But how can the task be accomplished in the **worst** way, so that the route taken is the longest?



Best Runner-up?

Eight players take part in a knockout tennis tournament. In the first round the eight players are randomly paired and four winners proceed to the semi-finals.

These four are again randomly paired with the two winners going forward to play against each other in the final to produce a champion and a runner-up.

Imagine that the eight players have a defined strength, (as every material object has its weight), and that the stronger player **always** beats the weaker one.

This kind of knockout tournament will certainly produce a fair champion, but what is the probability that the runner-up is in fact the second strongest player?



Railway Engineer

Four cities lie at the corners of a square with sides of length 100km.

Design a rail network that connects the cities so that a minimum length of rail is constructed.

(You have heard a rival engineer talking about a network that uses less than 280km of track.

Could this possibly be true?)



Fishpond

An ichthyologist wanted to estimate the number of fish in a pond that were suitable to be caught.

He threw a net into the pond and found 30 such fish. He marked each of them with a suitable colour and threw them all back into the pond.

The next day he threw the same net into the pond and caught 40 fish, two of which were marked.

How did he then compute an estimate for the number of fish in the pool?



Triangle Areas

Which of these triangles has the largest area?

- sides of 5cm, 5cm and 4cm
- sides of 5cm, 5cm and 5cm
- sides of 5cm, 5cm and 6cm
- sides of 5cm, 5cm and 7cm
- sides of 5cm, 5cm and 8cm



Ten-digit Numbers

A ten-digit number consists only of the digits 0,1 and 2 and consecutive digits are different.

The number does not begin with a zero.

How many different ten-digit numbers of this type can be made?



Hungry Goat

A goat is tethered by a 6 metre rope to the outside corner of a shed measuring 4 metres by 5 metres in a grassy field.

What area of grass can the goat graze?



Creepy Crawlies

Barney collects lizards, beetles and worms.

He has more worms than he has lizards and beetles together.

Altogether in his collection there are 12 heads and 26 legs.

How many lizards does Barney have?



Swimming Pool

Sarah has three hosepipes that she can use to fill her swimming pool.

The large hosepipe can fill the pool in 3 days

The medium hosepipe can fill the pool in 4 days.

The small hosepipe can fill the pool in 5 days.

How long will it take to fill the pool if Sarah uses all three hosepipes together?



Archimedes' Arbelos

The diagram shows an arbelos, so called because it looks like a tailor's knife of that name.

The shape is made of semicircles.

Find the area of the arbelos in terms of the distance marked h .

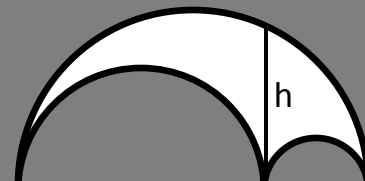

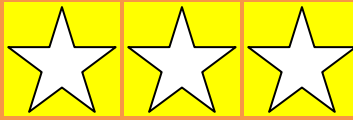

Population Growth

- If a population grows by 10% of its current size each month, how long will it take to double its size?
- If a population shrinks by 10% of its current size each month, how long will it take to halve its size?
- If a population alternately grows by 10% and then shrinks by 10% in successive months, what happens in the long run?



Old Car

An old, broken-down car has to travel a two-kilometre route, up and down a hill.

Because it is so old, the car travels the first kilometre, uphill, at an average speed of 15 km/h.

How fast must it travel on the downhill part so as to achieve an average speed of 30 km/h for the whole journey?



Medieval Locks

A certain village in medieval times had all the valuables locked in a chest in the church. The chest had a number of locks on it, each with its own individual and distinct key. The aim of the village was to ensure that any three people in the village would amongst them have enough keys to open the chest, but no two people would be able to.

How many locks are required and how many keys?



Lost in the Outback

A man lost on the Nullarbor Plain in Australia hears a train whistle due West of him.

He cannot see the train but knows that it runs on a very long, very straight track.

His only chance to avoid perishing from thirst is to reach
the track before the train has passed.

Assuming that he and the train travel at (different but) constant speeds,
in which direction should he walk?



Fitness Fanatics

Fred and Frank are two fitness fanatics on a run from A to B. Fred runs half the way and walks the other half. Frank runs for half the time and walks for the other half. They both run and walk at the same speeds. Who finishes first?

Francis joins them and teaches them to jog. Fred now runs one-third of the way, jogs one-third of the way and walks the rest, while Frank jogs for one-third of the time, runs for one-third and walks the rest. Who finishes first? Has Francis helped them to finish sooner or later than previously?



Desert Crossing

It takes nine days to walk across a desert.

A man must deliver a message to the other side, where no food or water is available, and then return.

One man can carry enough food and water to last for 12 days.

Food and water may be buried and collected on the way back.

There are two men ready to set out.

How quickly can the message be delivered?

No man must go short of food or water!



Restaurant Bill

My favourite restaurant gives me a 10% discount.

But to the cost of the meal must be added 17.5% VAT and a 12% service charge.

If the percentages are to be worked out in turn (with each percentage, whether addition or discount, being based on the previous answer), which order of working leaves me with the least to pay?



Palindromes

A number like 12321 is called a **palindrome** because it reads the same backwards as forwards.

A friend of mine claims that all palindromes with four digits are exactly divisible by 11.

Are they?

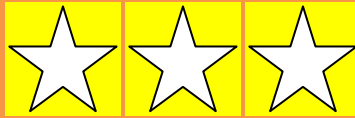

Multiplication Digits 4

Use the digits 1, 2, 3, 4, 5, 6 once each to complete this multiplication.

Explain why there is only **one** solution

$$\begin{array}{r} \square \quad \square \\ \times \quad \square \\ \hline \square \quad \square \quad \square \end{array}$$



Multiplication Digits 5

Is it possible to use the digits 1, 2, 3, 4, 5, 6, 7 once each to complete this multiplication? **Justify** your answer.

$$\begin{array}{r} \square \quad \square \quad \square \\ \times \quad \square \\ \hline \square \quad \square \quad \square \end{array}$$



Four Circles

What fraction of the area of the equilateral triangle is covered by the four circles?

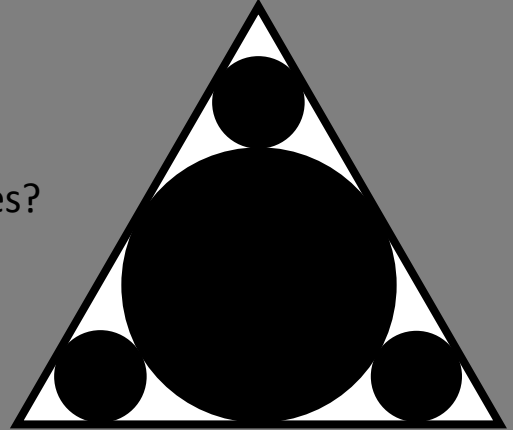

Faster Train

If a train had travelled 5 km/h faster it would have taken 1 hour less to travel 210 km.

How long did the journey actually take?



Train on a Bridge

A train 140 metres long takes 8 seconds to pass completely over a bridge which is 36 metres long.

Find the speed of the train in km/h



Three Circles

What fraction of the area of the equilateral triangle is covered by the three circles?

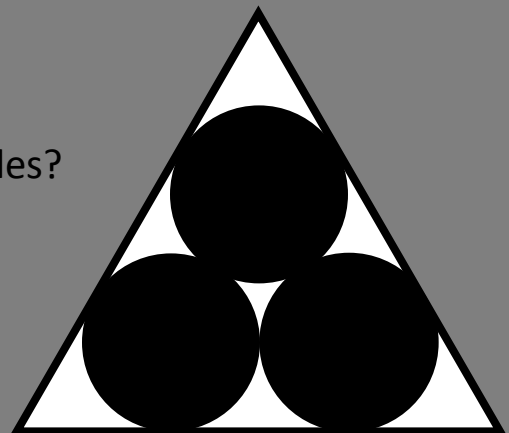



Two Classes

- In a class of 30 students there are 22 students who are right-handed and there are 14 girls.
What is the **smallest** number of girls who could be right-handed?
- In another class, 56% of the students are girls.
What is the **smallest** number of students the class could contain?



Mice & Chickens

- If five mice can eat five kilograms of cheese in five minutes, how long would it take fifty mice to eat fifty kilograms of cheese?
- If one-and-a-half chickens can lay one-and-a-half eggs in one-and-a-half days, then how many eggs will six chickens lay in six days?



Addition Digits 5

Work out the missing digits in these addition sums.

$$\begin{array}{r}
 9 \quad \square \\
 \square \quad 4 \\
 + \quad 9 \quad 3 \\
 \hline
 1 \quad \square \quad 9
 \end{array}$$

$$\begin{array}{r}
 6 \quad \square \quad 7 \\
 \square \quad 6 \quad 8 \\
 + \quad 3 \quad 9 \quad \square \\
 \hline
 2 \quad \square \quad 1 \quad 1
 \end{array}$$



Subtraction Digits 2

Work out the missing digits in these subtraction questions

$$\begin{array}{r}
 \square \quad 3 \quad \square \\
 - \quad 3 \quad \square \quad 6 \\
 \hline
 1 \quad 3 \quad 5
 \end{array}$$

$$\begin{array}{r}
 \square \quad \square \quad 4 \\
 - \quad 7 \quad 4 \quad \square \\
 \hline
 7 \quad 5
 \end{array}$$



Division Digits 1

Work out the missing digits in these division questions

$$\begin{array}{r} 15 \\ 7 \overline{) 1 \square \square} \end{array}$$

$$\begin{array}{r} 2\square \\ 8 \overline{) \square 3 \square} \end{array}$$



How Much?

One apple and one bottle of water costs \$4

Two apples and two ice creams costs \$9

One ice cream and one bottle of water costs \$2

- What would one apple, one bottle of water and one ice cream cost ?
- What does each item cost separately ?



Mathlete

In a race in which there are five other runners you overtake the person in fifth place. What place are you in now?

If you overtake the person third from last, what place are you in now?

What place are you in if you are the first person to overtake the person in last place? Explain how this could happen.



Animalympics

- In 2009 Usain Bolt ran 100 metres in 9.58 seconds
- In 2012 a female cheetah called Sarah ran 100 metres in 5.95 seconds
- Calculate Usain Bolt's and Sarah's average speeds in km / h
- If Sarah had run against Usain Bolt in the same race, can you **estimate** how far Usain Bolt would have been behind Sarah when she crossed the finish line? Have you made any assumptions?



Addition Digits 1

Work out the missing digits in these addition sums.

$$\begin{array}{r} 8 \quad \square \\ + \quad \square \quad 4 \\ \hline \square \quad 7 \end{array}$$

$$\begin{array}{r} \square \quad 7 \\ + \quad 7 \quad \square \\ \hline \square \quad 3 \end{array}$$



Addition Digits 2

Work out the missing digits in these addition sums.

$$\begin{array}{r} 3 \quad \square \\ + \quad \square \quad 8 \\ \hline \square \quad 1 \quad 1 \end{array}$$

$$\begin{array}{r} \square \quad 2 \\ + \quad 8 \quad \square \\ \hline \square \quad 0 \quad 1 \end{array}$$



Subtraction Digits 1

Work out the missing digits in these subtraction questions

$$\begin{array}{r}
 1 \quad \square \quad 3 \quad 8 \\
 - \quad \quad \quad 6 \quad \square \\
 \hline
 \square \quad 0 \quad \square \quad 0
 \end{array}$$

$$\begin{array}{r}
 3 \quad \square \quad 4 \\
 - \quad \square \quad 2 \quad \square \\
 \hline
 1 \quad 8 \quad 6
 \end{array}$$



Addition Digits 4

Work out the missing digits in these addition sums.

$$\begin{array}{r}
 6 \quad 9 \\
 \square \quad 5 \\
 + \quad 7 \quad \square \\
 \hline
 \square \quad 4 \quad 3
 \end{array}$$

$$\begin{array}{r}
 2 \quad \square \\
 \square \quad 4 \\
 + \quad 8 \quad 4 \\
 \hline
 2 \quad \square \quad 2
 \end{array}$$



Division Digits 2

Work out the missing digits in these division questions

$$12 \overline{) 6 \square 8}$$

$$\square 2 \overline{) 2 \square 2}$$

$$3 \square \overline{) \square \square \square}$$



Halfway between...

- Which number is halfway between 1 and 3
- Which number is halfway between 1 and 4
- Which number is halfway between 1 and 10
- Which number is halfway between 0.1 and 0.2
- Which number is halfway between - 3 and 5
- Which number is halfway between $\frac{1}{2}$ and $\frac{1}{4}$ (the answer is not $\frac{1}{3}$)



Multiplication Digits 2

Find **all** the solutions to these multiplication questions

and **prove** that you have found them all

$$\begin{array}{r}
 2 \quad \square \\
 \times \quad \square \\
 \hline
 2 \quad \square \quad 4
 \end{array}$$

$$\begin{array}{r}
 \square \quad \square \\
 \times \quad 6 \\
 \hline
 3 \quad \square \quad 2
 \end{array}$$

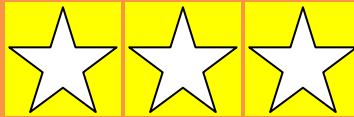

Multiplication Digits 3

Find **all** the solutions to these multiplication questions

and **prove** that you have found them all

$$\begin{array}{r}
 \square \quad 6 \quad \square \\
 \times \quad \square \\
 \hline
 4 \quad \square \quad 5
 \end{array}$$

$$\begin{array}{r}
 \square \quad 6 \quad \square \\
 \times \quad \square \\
 \hline
 \square \quad 7 \quad \square \quad 3
 \end{array}$$



Clock Angles

- What angle does the minute hand turn through between 2:00 and 2:30
- What angle does the hour hand turn through between 3:00 and 3:30
- What is the angle between the two hands of a clock at 4:30
- Give another time when the angle between the two hands is the same as when the time is 4:30



Addition Digits 3

Work out the missing digits in these addition sums.

Explain why there is **only one solution** for each question.

$$\begin{array}{r} \square \quad 5 \\ + \quad \quad \square \\ \hline \square \quad \square \quad 3 \end{array}$$

$$\begin{array}{r} \square \quad 3 \\ + \quad 2 \quad \square \\ \hline \square \quad 1 \quad 0 \end{array}$$



Time to Think

Which is longer ?

- one million seconds or ten days
- one million minutes or one hundred weeks
- one million hours or a century



Factorial Time !

! is the factorial symbol

6! means $1 \times 2 \times 3 \times 4 \times 5 \times 6$

- How long is 4! hours
- How long is 5! minutes
- How long is 10! seconds



Multiplication Digits 1

Find **all** the solutions to these multiplication questions

and **prove** that you have found them all

$$\begin{array}{r} \square \quad 4 \\ \times \quad \square \\ \hline \square \quad 8 \quad 6 \end{array}$$

$$\begin{array}{r} \square \quad 7 \\ \times \quad \square \\ \hline 2 \quad \square \quad 8 \end{array}$$



xxxx Party

I am 33 years, 33 months, 33 weeks and 33 days old.

How old, in years, was I on my last birthday?

When is your next x years, x months, x weeks, x days celebration party ?